

LEGEND Grade 80 Weld On Lifting Point

Legend Grade 80 Weld On Lifting Lugs can be welded onto any carbon steel surface as a lifting point, as a fixed anchor point for spreader beam attachment, or as an anchor point for load restraint applications.

All Legend Grade 80 hooks and components feature clear distinguishing marks for easy identification.

- Surface Finish: Painted Yellow
- Safety Factor: 4:1
- Complies to AS 3776
- Welding must always be carried out by a qualified welder under AS 1554.1
- Test Certificates available upon request.

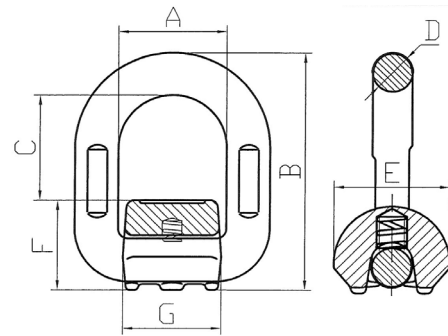

Item Code:	WLL	Dimensions							Weight	Pack Qty
		A	B	C	D	E	F	G		
	T	mm	mm	mm	mm	mm	mm	mm	kg	pc
L-WLP-01	1.12	41	78.5	35	13	38	33.5	37	0.47	50
L-WLP-03	3.15	46	94	42	17	43	37	44	0.69	30
L-WLP-05	5.3	55	118	48	22	61	50	50	1.46	15
L-WLP-08	8	70	141	62	26.5	70.5	54	66	2.52	10

Specifications and dimensions are subject to change without notice.