

LEGEND Grade 80 Container Hook

Legend Grade 80 Container Hooks are purpose-built hooks designed specifically for lifting containers by connecting to twist lock pockets. These hooks feature a large diameter eye that accommodates a wide range of compatible hooks, ensuring versatility and ease of use. They are available in both left and right-hand configurations.

All Legend Grade 80 hooks and components feature clear distinguishing marks for easy identification.

- Surface Finish: Painted Yellow
- Safety Factor: 4:1
- Complies to AS 3776
- Test Certificates available upon request.

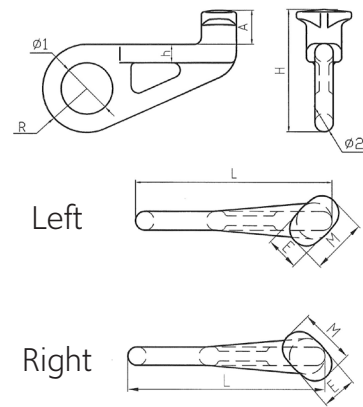

Item Code:	Type	WLL	Dimensions									Weight	Pack Qty	
			A	M	H	h	E	R	Ø1	Ø2	L			
		T	mm	mm	mm	mm	mm	mm	mm	mm	mm	mm	kg	pc
L80-CH-L	Left	12.5	46	75	166	25	48	60	70	25	265	4.125	4	
L80-CH-R	Right	12.5	46	75	166	25	48	60	70	25	265	4.125	4	

Specifications and dimensions are subject to change without notice.